

## RADIUS DIES

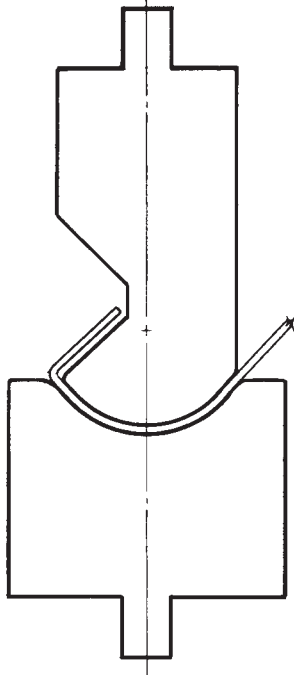

SET 101



Forming a radius in a sheet having a preformed return flange is accomplished by die set nos. 101, 102.

SET 102

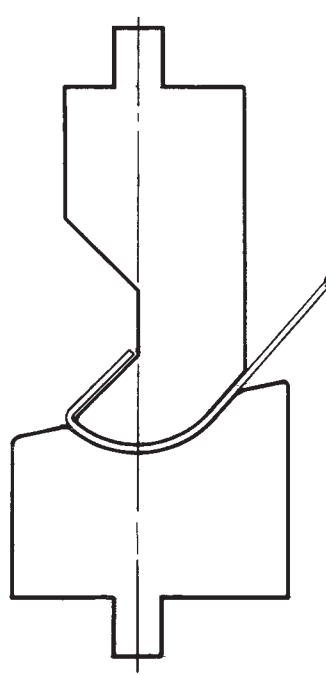

SET 103

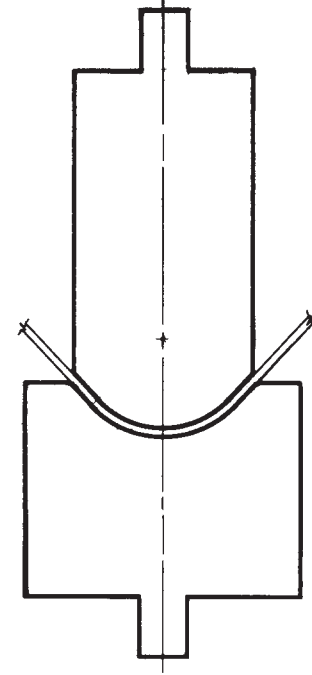

Form fitting radius die set #103 is used primarily for small radius bends on light ga. materials.

SET 104

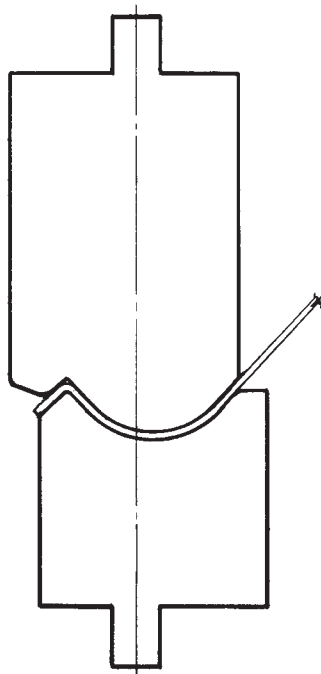

Outside flange on a radius bend can be formed in one stroke if springback is not too great.

SET 105

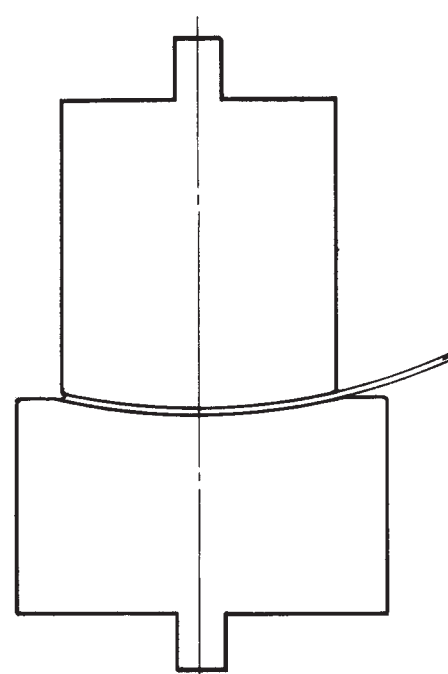

For radii larger than 1½" set #105 is ideal, this set is also used to radius the edge of a sheet prior to a rolling operation.