

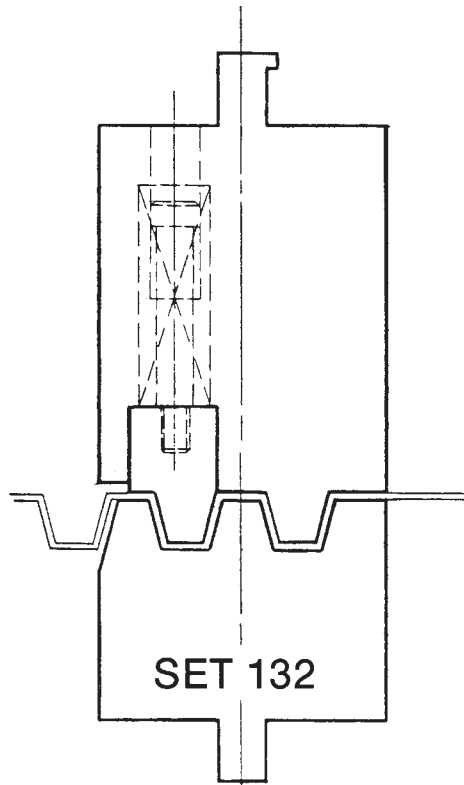

CORRUGATING DIES

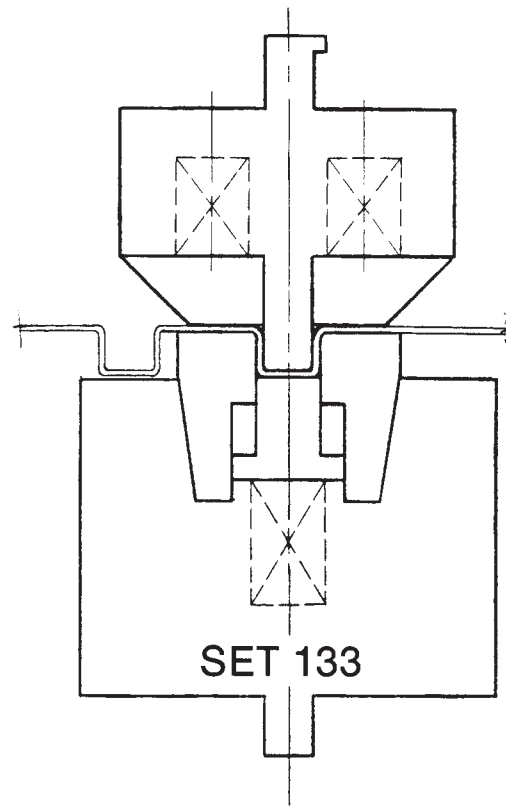

For high production, continuous corrugating and where constant accuracy is necessary, die sets #132 and #134 are recommended. Die set #132 is for continuous angular corrugating and die set #134 is for continuous radius corrugating. After the first operation, the spring loaded pad locates the sheet and the dies become self gauging.

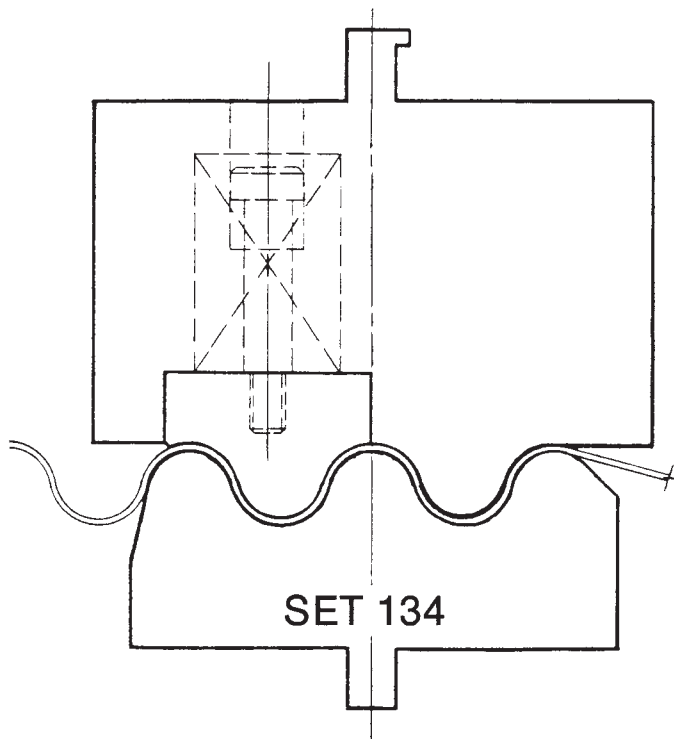

Die set #133 will form accurate corrugations in light gauge materials. Spring pressure pads assure positive stripping and release wedges prevent marring of the formed material.

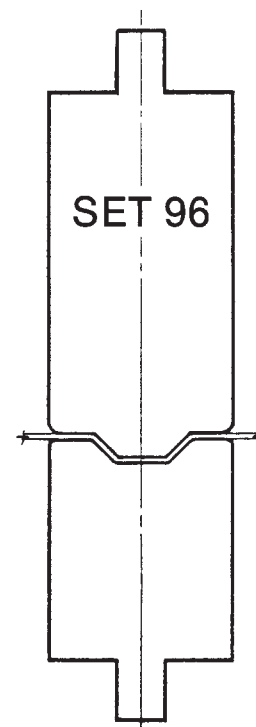

Small open hat channels can be produced in die set #96. Depth of channel must be shallow to avoid trapping excess stock between punch and die, thus causing irregularities of shape.