

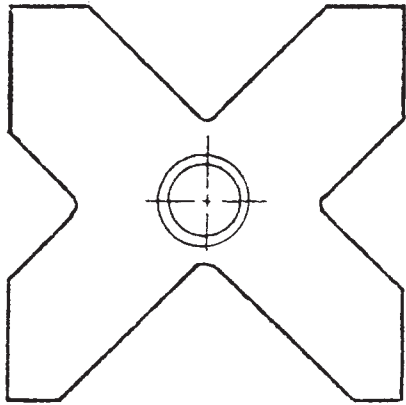

# FOUR WAY DIES AND HOLDERS

Note-  
Openings less than 1" are normally made 90°.  
Openings 1" and over are normally made 85°.



Die. No.	Block Size		4 Die Openings		
F 135	2.25	.50	.75	1.00	1.25
F 136	2.75	.625	.875	1.125	1.50
F 137	3.25	.75	1.00	1.50	2.00
F 138	3.75	.875	1.125	2.00	2.50
F 139	4.25	1.00	1.50	2.00	3.00
F 140	4.75	1.00	1.25	2.50	3.00
F 141	5.25	1.00	2.00	3.00	4.00
F 142	5.75	1.25	2.00	3.00	4.00
F 143	6.75	2.00	3.00	4.00	5.00
F 144	7.75	2.00	3.00	4.00	6.00
F 145	10.00	2.00	4.00	6.00	8.00
F 146	12.00	3.00	4.00	6.00	10.00

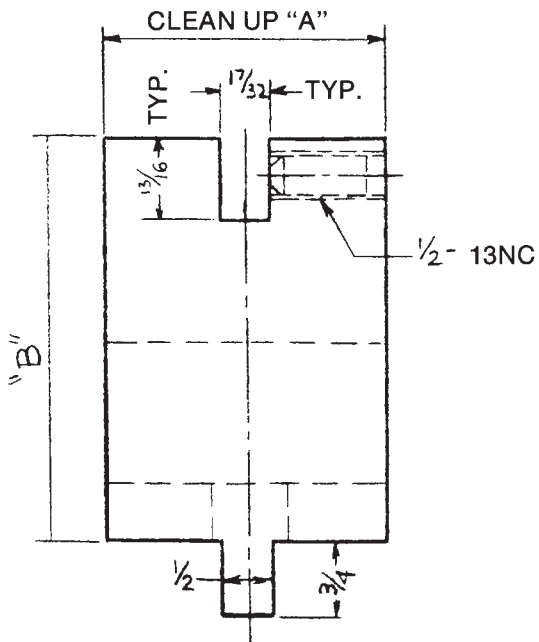

\*Crowning of all die holders can be supplied. Ask your sales person.

Any Die holder 4" high or over can be furnished with half moon burnouts for mounting.

NO.	A	B
H 147	2	1 1/2
H 148	2	2
H 149	2	3
H 150	2	4
H 151	2	5
H 152	3	1 1/2
H 153	3	2
H 154	3	3
H 155	3	4
H 156	3	5
H 157	4	2
H 158	4	3
H 159	4	4
H 160	4	5
H 161	5	2
H 162	5	3
H 163	5	4
H 164	5	5

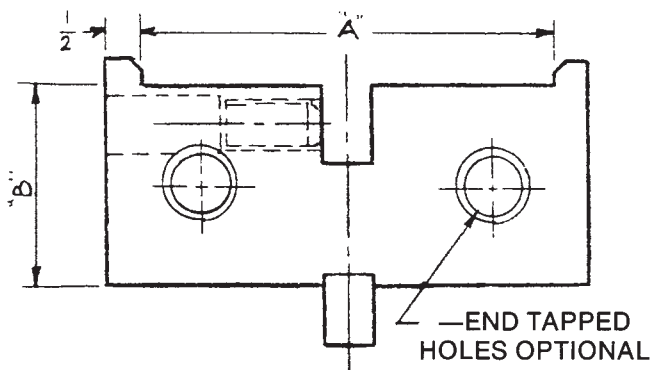

## THREE AND FOUR WAY COMBINATION DIE HOLDERS

NO.	A	B
H 165	2 1/4	3 1/2
H 166	2 1/4	5
H 167	2 3/4	3 1/2
H 168	2 3/4	5
H 169	3 1/4	3 1/2
H 170	3 1/4	5
H 171	3 3/4	3 1/2
H 172	3 3/4	5
H 173	4 1/4	3 1/2
H 174	4 1/4	5

NO.	A	B
H 175	4 3/4	3 1/2
H 176	4 3/4	5
H 177	5 1/4	3 1/2
H 178	5 1/4	5
H 179	5 3/4	3 1/2
H 180	5 3/4	5
H 181	6 3/4	3 1/2
H 182	7 3/4	3 1/2
H 183	10	3 1/2
H 184	12	3 1/2