

## RAM ADAPTERS

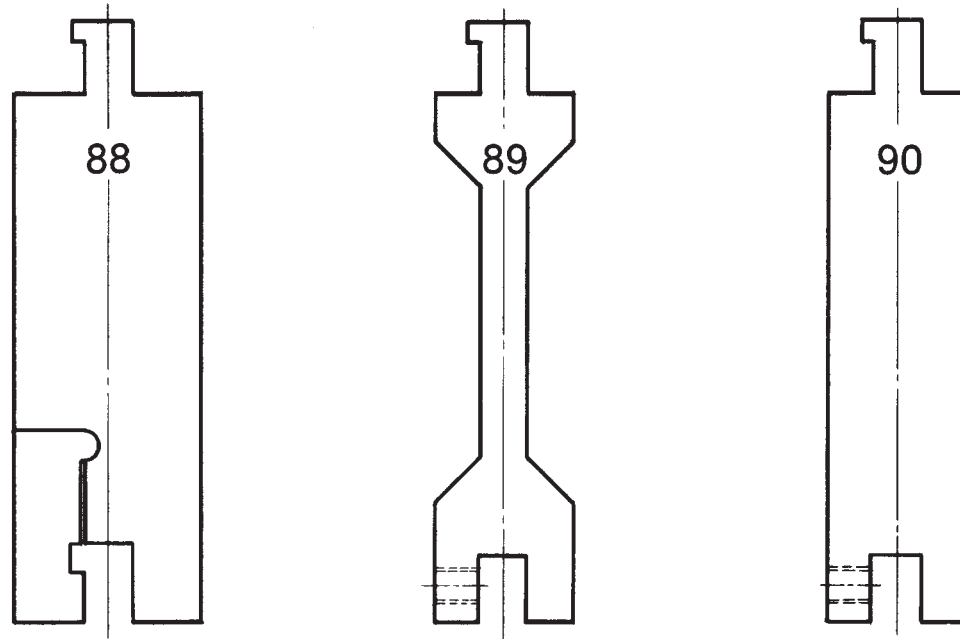

Ram adapters are mounted to the press brake ram and are used to fill the die space if ram adjustment is insufficient. Ram adapters can be made any height or width to suit conditions.

## AIR FORMING ADJUSTABLE FEMALE DIE

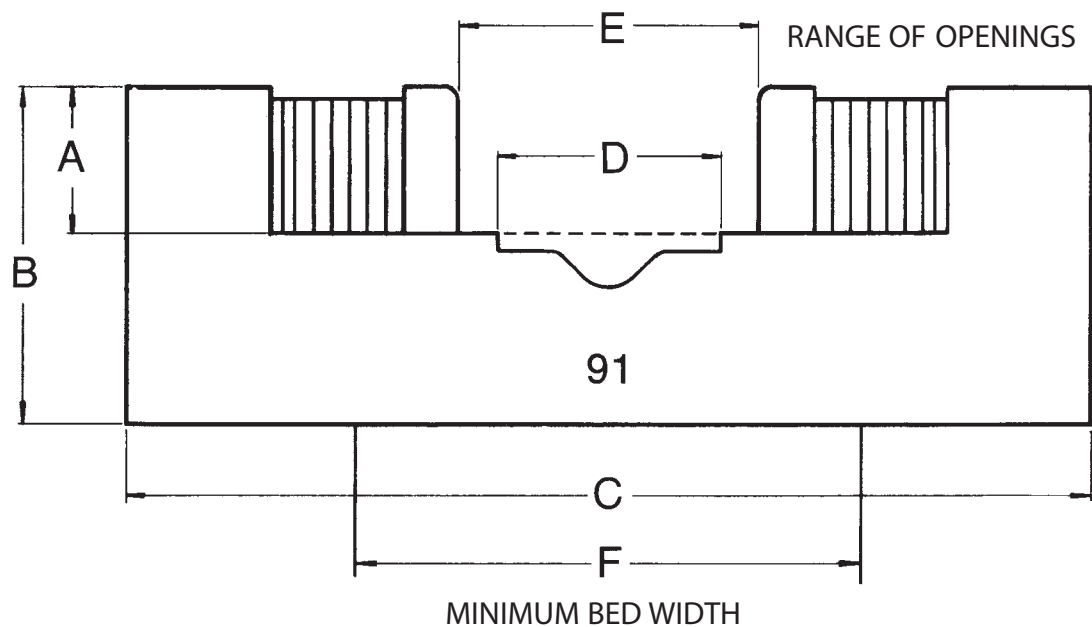

Die No. 91 could be considered to be one of the most versatile additions to a press brake. With this type of tool, openings can be arranged from 1/4" to 15". Spacers are provided to produce the required opening. Slotted spacers allow for easy removal to change the die opening. When not in use, spacers are positioned at sides of the die block. These dies can be furnished in solid lengths or sectioned for easier handling.

Die No.	A	B	C	D	E	F
91 A	1-5/8"	2-7/8"	8"	NONE	1/4" - 3-1/2"	3-1/8"
91 B	2-1/4"	4-1/8"	12"	NONE	1/2" - 5"	5"
91 C	2-7/8"	5-3/4"	16-1/4"	3-1/4"	3" - 8"	8"
91 D	3-1/4"	7"	9-1/2"	4-1/4"	4" - 10"	10"
91 E	4-1/4"	10"	22-3/4"	5-1/4"	5" - 12"	12"
91 F	6-3/4"	10-1/2"	28"	7-3/4"	8" - 15"	15"